

DCDC coverters

PCB Colours

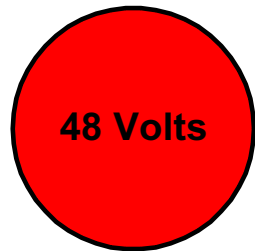

Turn On Max = 68.6V
Turn On Min = 46.8V

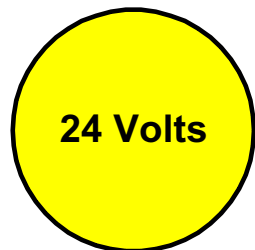

Turn On Max = 34.2V
Turn On Min = 23.4V

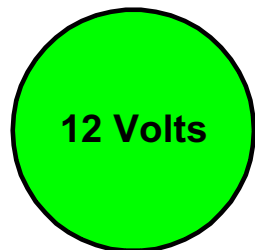

Turn On Max = 17.1V
Turn On Min = 11.7V

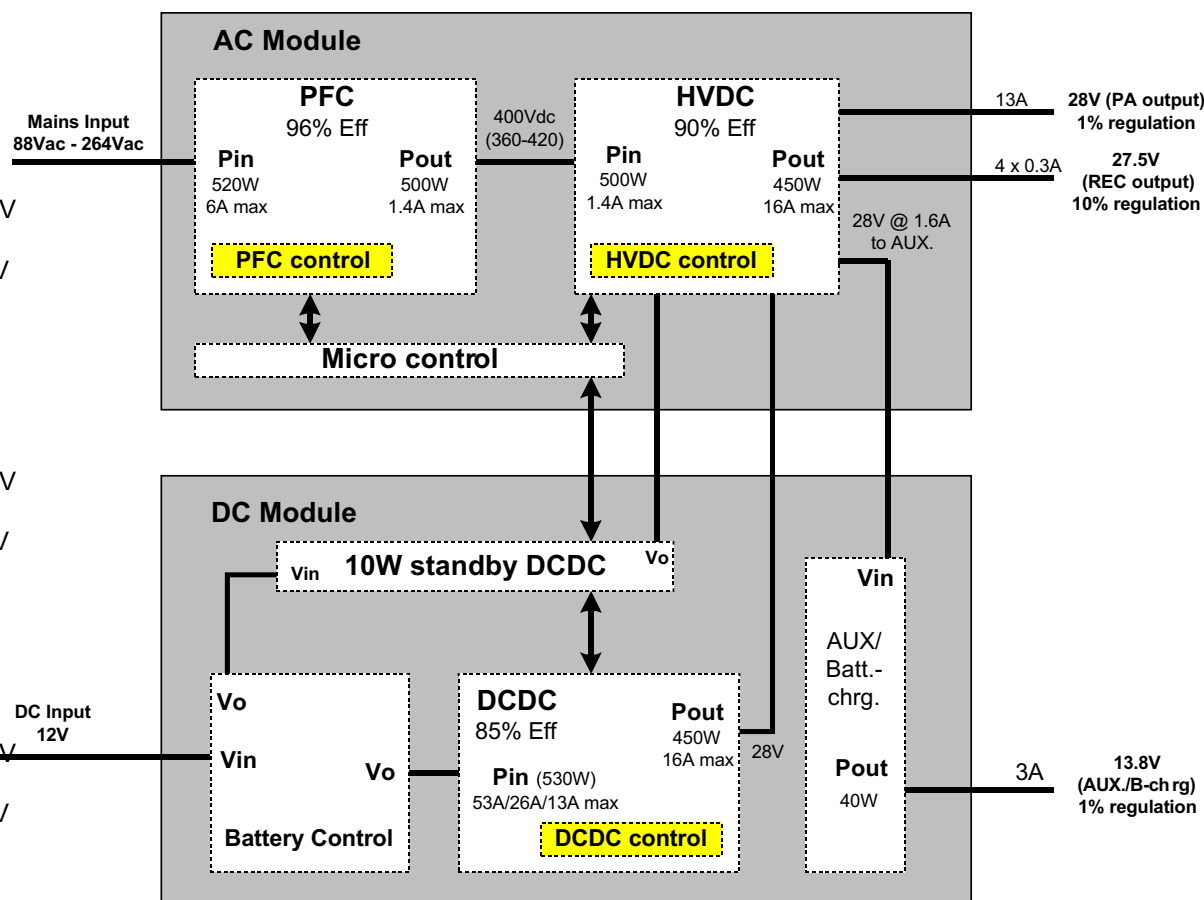

Alarms

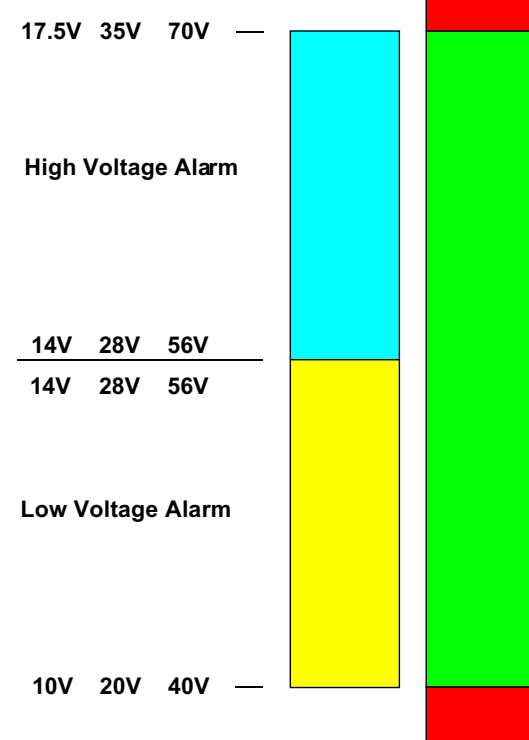

Power Configurations

